

# CARVERaudio.com

A Website Devoted to the Legacy of Bob Carver's Electronics

This, and all manuals found on CARVERaudio.com have been painstakingly scanned, compiled, cataloged and archived by our [dedicated forum members](#), for the benefit of all Carver audio fanatics. These manuals are NOT intended for re-sale. If you should find these manuals "For Sale" on any website, please report your findings to us, so we may have them removed.

# CARVERaudio.com

# CARVER

CT-6  
Sonic Holography<sup>®</sup>/ACCD  
Tuner/Preamplifier

Owner's Manual

CARVER

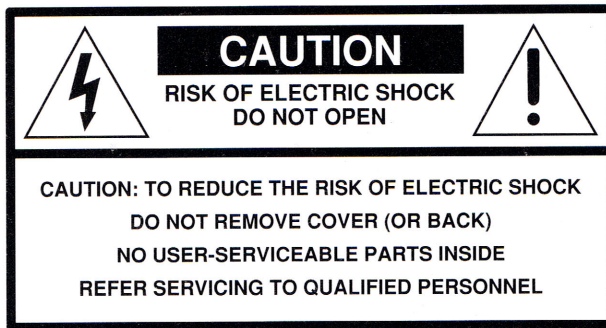

The lightning flash with arrowhead symbol within an equilateral triangle is intended to alert the user to the presence of uninsulated "dangerous voltage" within the product's enclosure, that may be of sufficient magnitude to constitute a risk of electric shock to persons.



The exclamation point within an equilateral triangle is intended to alert the user of the presence of important operating and maintenance (servicing) instructions in the literature accompanying the appliance.

## Safety Instructions

1. Read Instructions — All the safety and operation instructions should be read before the Carver Component is operated.
2. Retain Instructions — The safety and operating instructions should be kept for future reference.
3. Heed Warnings — All warnings on the Component and in these operating instructions should be followed.
4. Follow Instructions — All operating and other instructions should be followed.
5. Water and Moisture — The Component should not be used near water - for example, near a bathtub, washbowl, kitchen sink, laundry tub, in a wet basement, or near a swimming pool, etc.
6. Ventilation — The Component should be situated so that its location or position does not interfere with its proper ventilation. For example, the Component should not be situated on a bed, sofa, rug, or similar surface that may block any ventilation openings; or placed in a built-in installation such as a bookcase or cabinet that may impede the flow of air through ventilation openings.
7. Heat — The Component should be situated away from heat sources such as radiators, or other devices which produce heat.
8. Power Sources — The Component should be connected to a power supply only of the type described in these operation instructions or as marked on the Component.
9. Power Cord Protection — Power-supply cords should be routed so that they are not likely to be walked upon or pinched by items placed upon or against them, paying particular attention to cords at plugs, convenience receptacles, and the point where they exit the Component.

10. Cleaning — The Component should be cleaned only as recommended in this manual.

11. Non-use Periods — The power cord of the Component should be unplugged from the outlet when unused for a long period of time.

12. Object and Liquid Entry — Care should be taken so that objects do not fall into and liquids are not spilled into the inside of the Component.

13. Damage Requiring Service — The Component should be serviced only by qualified service personnel when:

- A. The power-supply cord or the plug has been damaged; or
- B. Objects have fallen, or liquid has spilled into the Component; or
- C. The Component has been exposed to rain; or
- D. The Component does not appear to operate normally or exhibits a marked change in performance; or
- E. The Component has been dropped, or its cabinet damaged.

14. Servicing — The user should not attempt to service the Component beyond those means de-

## PORTABLE CART WARNING



Carts and stands - The Component should be used only with a cart or stand that is recommended by the manufacturer. A Component and cart combination should be moved with care. Quick stops, excessive force, and uneven surfaces may cause the Component and cart combination to overturn.

scribed in this operating manual. All other servicing should be referred to qualified service personnel.

15. To prevent electric shock, do not use this polarized plug with an extension cord, receptacle or other outlet unless the blades can be fully inserted to prevent blade exposure.

Pour prévenir les chocs électriques ne pas utiliser cette fiche polarisée avec un prolongateur, un prise de courant ou une autre sortie de courant, sauf si les lames peuvent être insérées à fond sans laisser aucune partie à découvert.

16. Grounding or Polarization - Precautions should be taken so that the grounding or polarization means of the Component is not defeated.

17. Internal/External Voltage Selectors — Internal or external line voltage selector switches, if any, should only be reset and re-equipped with a proper plug for alternate voltage by a qualified service technician. See an Authorized Carver Dealer for more information.

18. Attachment Plugs for Alternate Line Voltage (Dual voltage models only)— See your Authorized Carver Dealer for information on the attachment plug for alternate voltage use. This pertains to dual-voltage units only.

This apparatus does not exceed the Class A/Class B (whichever is applicable) limits for radio noise emissions from digital apparatus as set out in the radio interference regulations of the Canadian Department of Communications.

ATTENTION – Le présent appareil numérique n'émet pas de bruits radioélectriques dépassant les limites applicables aux appareils numériques de class A/de class B (selon le cas) prescrites dans le règlement sur le brouillage radioélectrique édicté par les ministere des communications du Canada.

WARNING – To reduce the risk of fire or electric shock, do not expose this appliance to rain or moisture.

**EXAMPLE OF ANTENNA GROUNDING ACCORDING TO NATIONAL ELECTRICAL CODE INSTRUCTIONS CONTAINED IN ARTICLE 810 - "RADIO AND TELEVISION EQUIPMENT"**

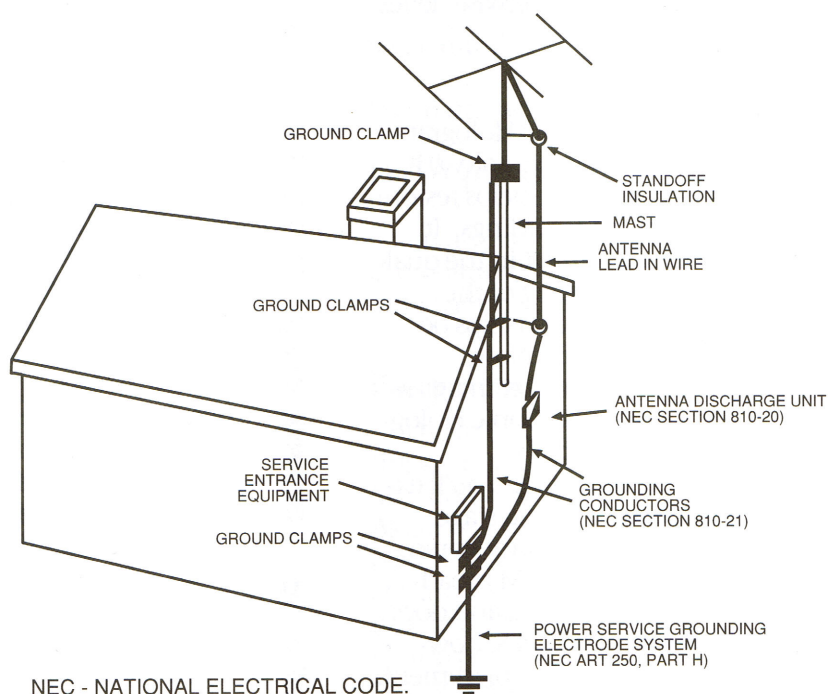

NOTE TO CATV INSTALLER  
 This reminder is to call the CATV system installer's attention to Article 820-22 of the NEC that provides guidelines for proper grounding and in particular, specifies that the cable ground shall be connected to the grounding system of the building as close to the point of cable entry as practical.

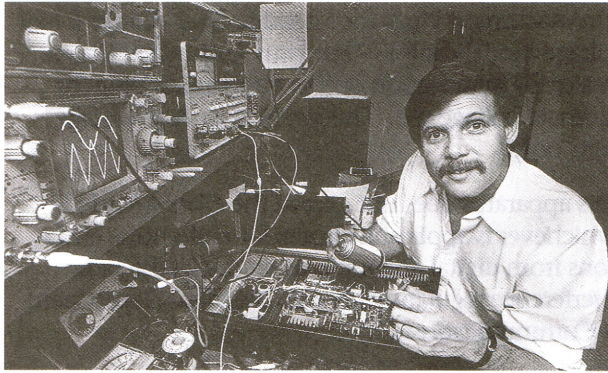

Congratulations on purchasing one of the most remarkable tuner/preamplifiers ever offered. A design that combines excellent overall sonic qualities, useful features and Carver exclusive technology in an ultra-slim line configuration.

### The basics

First and foremost, the CT-6 is a superb preamplifier with moving magnet phono stage and inputs for up to eight sound sources (four regular inputs plus two tape monitor loops). Distortion and noise are exceptionally low. Dynamic headroom is high enough to handle the most aggressively-recorded CD or LaserDisc. Moreover, we think that you'll be impressed with the CT-6's overall "sound", a subjective quality that otherwise defies quantification.

### Sonic Holography®

Next, we have incorporated a Sonic Hologram Generator into the CT-6. Sonic Holography® is an exclusive Carver invention which helps restore the true spacial characteristics of recordings. It can bring you an actual improvement in the quality of listening via complex processing of the stereo signals, and a change in relationships between the listener and loudspeakers. Now, instead of flat, between-the-loudspeaker imaging associated with conventional stereo, Sonic Holography® will paint a sonic picture that's remarkably believable and convincing. You'll experience a perceptible increase in sound stage depth as well as width. It works with any stereo input including CD's, tapes, records, FM broadcasts, VHS Hi-Fi video soundtracks, etc., and does not require additional speakers. It DOES, however, require careful set-up and speaker placement. In other words, you'll have to take some time and read the instructions carefully to fine tune Sonic Holography® to your room and speakers. . . but

the results can be absolutely astonishing. We get many letters from Carver owners who simply "cannot live without" the improvements Sonic Holography® makes on their favorite music.

### Remote control

That may not seem like such a big deal, but please note that we have chosen to use a motorized volume control rather than internal gain reduction circuitry. By motorizing what is essentially a standard, low-distortion potentiometer such as the type used in our Reference Preamplifiers, we can eliminate considerable circuitry which can affect the signal. Besides, with the lighted inset, the motorized volume control looks absolutely cool in a darkened room.

### Asymmetrical Charge-Coupled FM Detection

This circuitry (ACCD for short) can improve FM reception on stations which are plagued with multipath distortion. It works by analyzing small portions of the UN-distorted stereo portion of the station signal and then replacing the distorted portion with new, but accurate stereo sound. ACCD can't work miracles on really terrible reception, but it can make a significant difference on many stations.

### Made where?

Carver is American-owned and based in Lynnwood, Washington. Of the almost 300 people who work here, most are engaged in building Carver home, mobile and professional audio products. Carver's goal is and always will be to provide audiophile-quality products at affordable prices. Thus, we strive to take advantage of manufacturing economies and methods wherever possible. As a result, we DO use outside production facilities for some products and take great pains to indicate this on your packing box, but some people are still surprised. Suffice it to say that the CT-6 is American-designed and American-engineered and is the great value it is because we have chosen the most effective production source for the particular model.

### About this manual

In response to Carver customer suggestions, we're trying a new style of manual. It is designed to cover more possible hook-ups and better explain the operation of the CT-6. As a result, it may appear considerably more complicated than the

manual which comes with some preamplifiers. If you're not experienced in hooking up stereo equipment, we think that you will appreciate the detail to which we have gone. However, we've also provided a method by which the "advanced" user can quickly grasp the key points and differences of the CT-6. Important information is enclosed in boxes like the one below. Even if you don't read any other part of the manual, please check out each of these boxes before proceeding.

**Once again, thank you!**

There are quite a few tuner/preamplifier brands and models on the market today. We appreciate your choice of the CT-6. Its small size belies the wealth of features and great sound that it is capable of. I hope that you will have many years of listening enjoyment.

Sincerely,

Bob Carver



**STOP!**

**PLEASE READ THIS!**

**Key Points Are Highlighted in Boxes**

*Ultra-important information about hooking up and operating your CT-6 is enclosed in boxes like this one. If you're an experienced hi-fi buff and don't usually read manuals all the way through (or are just super-impatient), at least read all the info in the boxes throughout this manual. The CT-6 has some unique features which are not immediately obvious.*

# Hook-Up

**Save the packing box and your sales invoice!**

*The box is necessary for re-packing your CT-6 if it ever needs service (or if you move).*

*Keep the sales receipt from the store where you bought your CT-6 1) to establish the duration of your Warranty; 2) for insurance purposes.*

Upon opening the box, please check for any visible sign of damage that did not appear on the outside of the box. If you DO encounter what appears to be concealed damage, please consult your Carver Dealer before further unpacking or installing the unit.

Along with the steps noted above, take a moment and fill in the following information for convenient reference:

**Model CT-6 Tuner/Preamplifier**

Serial number \_\_\_\_\_

Purchased at \_\_\_\_\_

Date of purchase \_\_\_\_\_

Finally, take a moment to fill out and return the Warranty Card that came with your CT-6 Tuner/Preamplifier.

**Placement**

The real no-no's are listed on the first page of this manual. They include common sense stuff like "don't use the CT-6 in your swimming pool." Assuming your location is OK, the CT-6 can be placed in any position including vertically. Heat, at least in normal amounts, shouldn't be any problem. However, be sure not to block the CT-6's top panel ventilation areas. If you set another component on top of the CT-6, make sure that its "feet" sit squarely on top of the CT-6 so that there is at least a 1/4" gap between the component and the CT-6.

Also make sure that the CT-6 is not placed directly above power amplifiers with high heat output.

### Connection tips

We're about to launch into the actual nitty gritty patch cord frenzy that results when you get a new component. First, though, consider the following tips.

- Turn all other components OFF before making any connections.
- Make sure that "left is hooked to left and right is hooked to right" at each connection. The obvious way to assure this is to assign one hook-up cord plug color to left and the other to right. Generally RED is used to signify RIGHT. White, grey or black then represents left.
- Whenever possible, keep power cords away from signal cables (inputs from CD player, tape deck etc.) to prevent hum. This is especially important for phono cables which carry very weak signals. While hum is less of a problem today than it was in the past, noise can still find its way into your system if a component's power cord becomes too intimately wrapped up with a hook-up cable. Carver components' power cords are on the right side of the chassis (when viewed from the back). This allows you to bundle all the power cords and keep them separate from signal connections.
- Type of hook-up cords. Also called interconnects, patch cords or RCA cables. There are lots of different grades of hook-up cables. You can pay as much as \$30 per foot for some of them! Whether or not you get an incremental increase in sound quality with "audiophile" interconnects is up to your own ears. One further comment, though. Really CHEAP connection cables can sometimes DIS-connect themselves inside, causing a loss of sound in one channel or hum problems. Before you send a component in for service, swap hook-up cables to see if they're the culprit.

- DON'T PANIC. While there are no less than 18 sockets on the back of the CT-6, matching them up with your existing equipment is simple. Besides, you probably won't use all 18 sockets anyway.

### Hook-up...An overview

There are basically two kinds of connections on the CT-6 (or any other tuner/preamp for that matter):

*1-way and 2-way.*

*One-way connections simply route the signal from a sound source to the corresponding input on the back of the CT-6.*

1-way "incoming" connections are for:

- CD Player
- Video 1 (sound ONLY)
- Video 2 (sound ONLY)
- Turntable (PHONO)

The only 1-way "outgoing" connections are:

- Pre Out (to main system amplifier)

These are easy connections. We discuss a few of them in detail below. All you have to watch is making sure that "lefts go to lefts and rights go to rights."

*Two-way connections can get considerably more complicated. They center around the CT-6's tape functions and are referred to as tape monitor loops. "Loops" because a signal from the component goes out of the CT-6 as well as into it. 2-way connections may involve one or more of the following components:*

- Tape Deck 1
- Tape Deck 2
- Equalizer or other sound modification device
- Some models of Dolby Surround Sound decoder

If you're connecting any of the above to your CT-6, take special care to follow our instructions, illustrations and general free-form comments in the sections that follow.

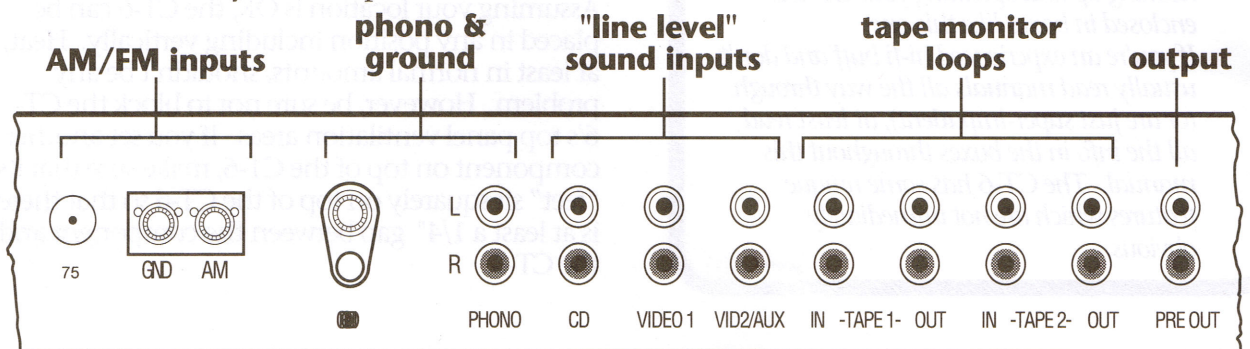

**Ultra-quick "can't wait" express hook-up diagram**

*Note that there are also several alternative hook-up possibilities you should also be aware of which allow remote control selection of tape monitor loops.*

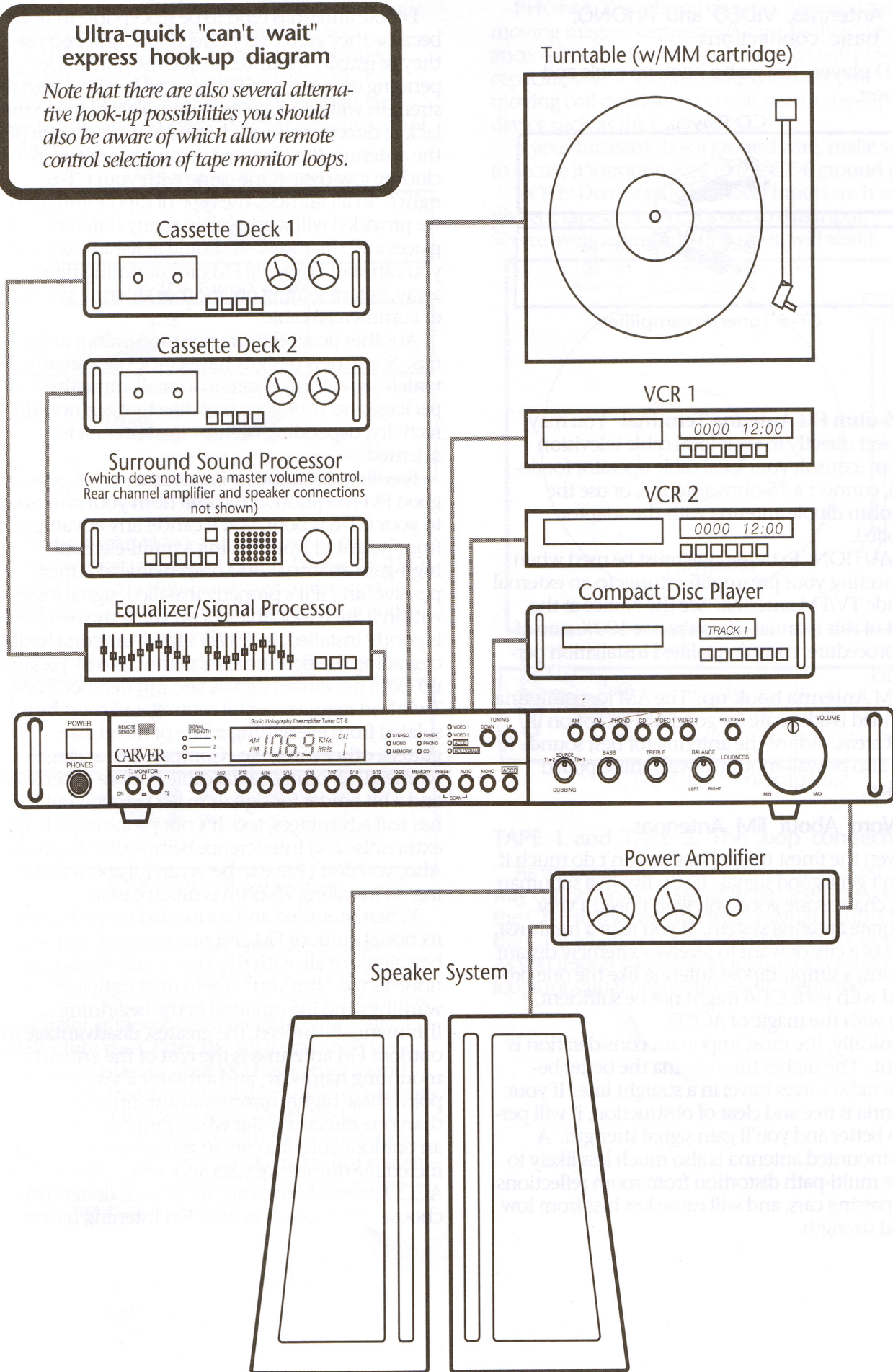



## CD, Antennas, VIDEO and PHONO: The basic connections

**CD player.** Just grab a hook-up cable and connect.

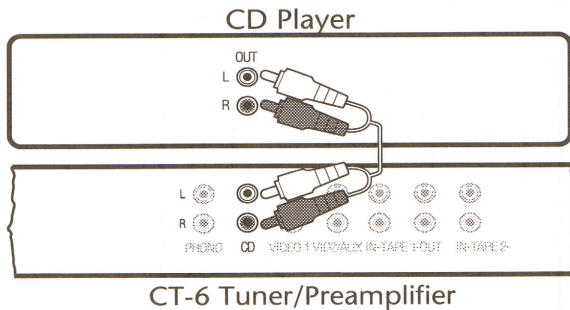

**75-ohm FM Antenna Terminal.** You may connect directly to your local cable television system (consult your local cable operator for details), connect a 75-ohm antenna, or use the 300-ohm dipole antenna with the adaptor supplied.

**CAUTION:** Extreme care must be used when connecting your preamplifier/tuner to an external outside TV/FM antenna. See the Notice at the front of this manual. If you're not 100% sure of the procedure, consult qualified installation personnel.

**AM Antenna hook-up.** The AM loop antenna provided is adequate for good AM reception in most areas. Adjust the antenna for best sound. It may also be wall-mounted with the supplied bracket.

### A Word About FM Antennas

Even the finest tuning section can't do much if it can't get a good signal. If you live in a suburban area, chances are good you won't need a very elaborate antenna system. If you're in a rural area, heart of a city or want to receive extremely distant stations, a simple dipole antenna like the one provided with your CT-6 might not be sufficient, even with the magic of ACCD.

Basically, the most important consideration is height. The higher the antenna the better because radio waves travel in a straight line. If your antenna is free and clear of obstruction, it will perform better and you'll gain signal strength. A roof-mounted antenna is also much less likely to cause multi-path distortion from room reflections and passing cars, and will cause less hiss from low signal strength.

Dipole antennas tend to be susceptible to noise because they aren't very directional, and because they're usually mounted inside the home. Depending on your specific area and location, signal strength will be adequate at best. This is due to the lack of directionality and, in most cases, height of the antenna. But there are some advantages, including low cost. (One came with your CT-6, right?) In all fairness, the type of dipole antenna we provided will work well in many different places and situations. It should at least be used so you can start enjoying FM programming right away, before settling on another antenna system or commercial cable.

Another possibility are powered indoor antennas. Some new designs have come out recently which provide high gain in a small, attractive package and your choice of directivity or non-directivity, depending on how the antenna is oriented.

Feedlines are another important part of getting good FM reception. If the link from your antenna to your CT-6 is poor, you'll cancel any advantage from height or from having a multi-element, high-gain antenna. 300-ohm twinlead is inexpensive, and if it's properly installed, signal losses within it are reasonable. However, if the twinlead is poorly installed, it can act like an antenna itself, degrading the performance of the CT-6 by picking up extra unwanted signals and interference noise. Twinlead requires careful routing and must be insulated from everything made of metal, like gutters, other wires, etc. Compared to average twinlead, 75-ohm coaxial cable is more expensive and a bit harder for signals to get through but it has real advantages, too. It's not prone to pick up extra noise and interference because it's shielded. Also, you don't have to be as careful about routing, so installing 75-ohm is much easier.

When mounted and connected properly, a directional outdoor FM antenna can provide the best signal of all, with the lowest interference and noise factor. But you have to do it right (see the warnings and information at the beginning of this manual). Indeed, the greatest disadvantage to outdoor FM antennas is the cost of the antenna, mounting hardware, and a rotator if you want to point these highly directional antennas in more than one direction. But when properly installed, an outdoor antenna can, in most areas pull in an incredible number of stations for the CT-6's ACCD processor to clean up. Which design you choose will depend on your FM listening habits

and, of course, your location. Consult with your Carver dealer for more antenna insights.

**VIDEO 1 & VIDEO 2.** These are for video *SOUND*, not picture. Sources include VCR's, LaserDisc players, MTS stereo TV's which have audio outputs and even "deluxe" remote control cable boxes.

Video sound source 2

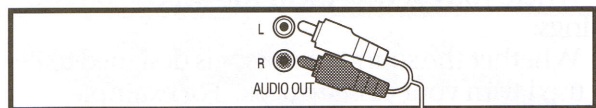

Video sound source 1

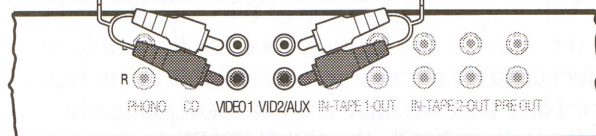
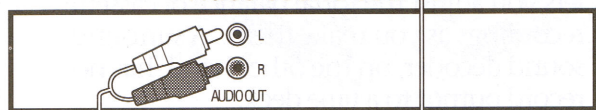

CT-6 Tuner/Preamplifier

Note: If your video sound source is mono (you'll see just one socket simply labeled AUDIO), add a "Y-cord" splitter as shown in the next illustration. They're available from many audio dealers or radio supply stores.

Monaural Video Sound Source

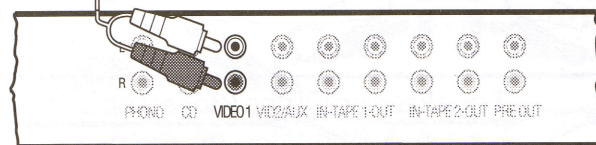
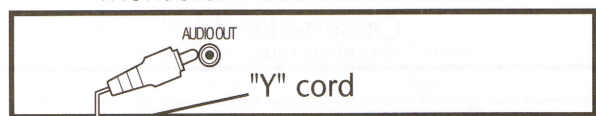

CT-6 Tuner/Preamplifier

### An observation about line level inputs

The CT-6's CD, VIDEO 1 and VIDEO 2 inputs can really be used for *any* line level sound source. Naturally, it's most convenient to plug your CD player into the CD input; still if you don't yet have a CD player — but DO have other sound sources feel free to connect them. We've encountered videophiles with three VCR's and a LaserDisc player. Tapists with four or five decks, some of which are only for playback. Just remember what you've connected where and use the CT-6's inputs as you see fit.

**PHONO.** This phono circuit is designed for moving magnet cartridges (Gain: 36dB; impedance: 47K ohms resistance in parallel with 150pf capacitance). If you are using a low-output moving coil cartridge, you will need a step-up device such as the Carver MCT.

If your turntable has a ground wire, make sure to secure it's ground wire to the CT-6 ground post.

**NOTE:** Do not plug line level inputs such as CD players, tape decks, VCR's etc. to this input. Severe overloading and distortion will result.

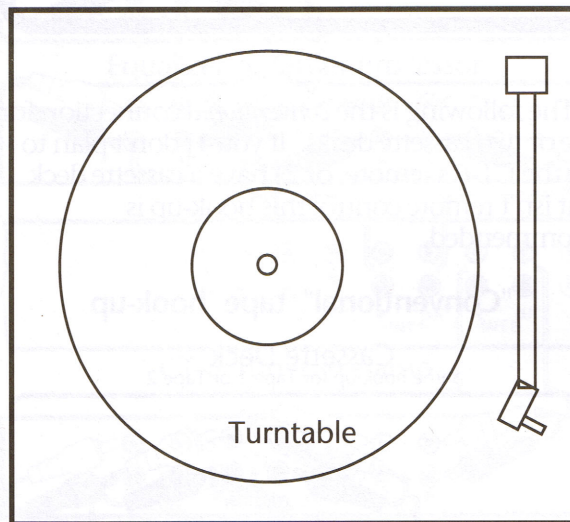

Make sure to connect turntable ground wire



CT-6 Tuner/Preamplifier

### TAPE 1 and TAPE 2: The loop connections

As we explained earlier, tape hook-ups are 2-way connections. A signal to be taped goes out of the CT-6 to the cassette deck; a signal returns to the CT-6 when you press the deck's PLAY button. As you'll soon see, these loops can beget their own loops for signal processing equipment, too.

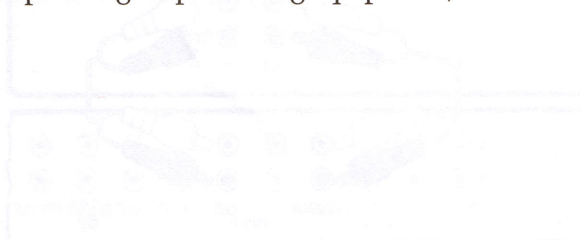

**Two DIFFERENT tape connection options**

*The CT-6's remote control does not have a tape monitor selector button. Thus, if you connect a deck in the conventional manner, you can't select it as a source by remote control. See the alternate hook-up below which returns the deck's signal into one of the VIDEO inputs.*

The following is the *conventional* connection for one or two cassette decks. If you 1) don't plan to use the CT-6's remote, or 2) have a cassette deck that isn't remote control this hook-up is recommended.

**"Conventional" tape hook-up**

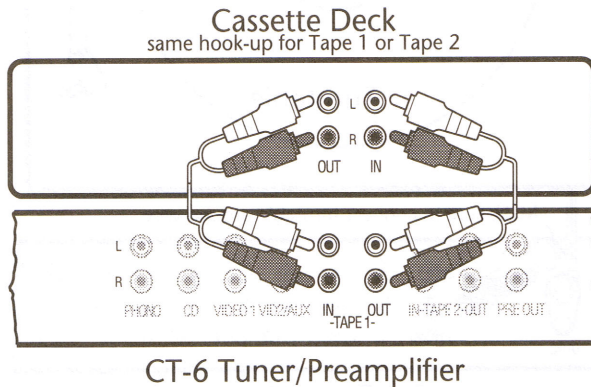

An alternative hook-up makes it possible to select a tape deck as a sound source via the CT-6's remote control.

**"Alternative" tape hook-up**

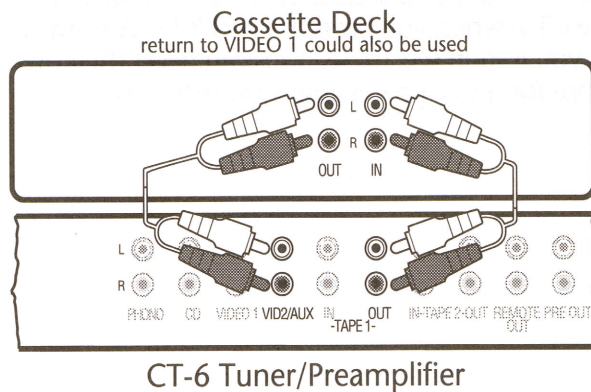

**Adding sound enhancement components**

There are all sorts of "black boxes" which you can add to your system. These include equalizers, dynamic expanders, hiss reduction units and multi-function units such as surround sound decoders and special equalization boxes which must be used with some speaker systems.

Where you connect them will depend on two things:

1. Whether the sound processor is designed to be used with your cassette deck. For example, many equalizers have a EQ TAPE button that lets you adjust the tonal balance of cassette recordings as you make them. A surround sound decoder, on the other hand, has no record output to a tape deck.
2. Whether you have one or two cassette decks.

If you want the sound processor to be able to affect cassette recordings, use the following hook-up. Note that we have shown the equalizer's output returning to the CT-6's TAPE 1 - IN. As indicated in our alternative connection diagram above, it could also be connected to VIDEO 1 or VIDEO 2. Either way, the signal processor is connected to the CT-6's tape monitor loop; then the cassette deck is connected to the signal processor's tape monitor loop.

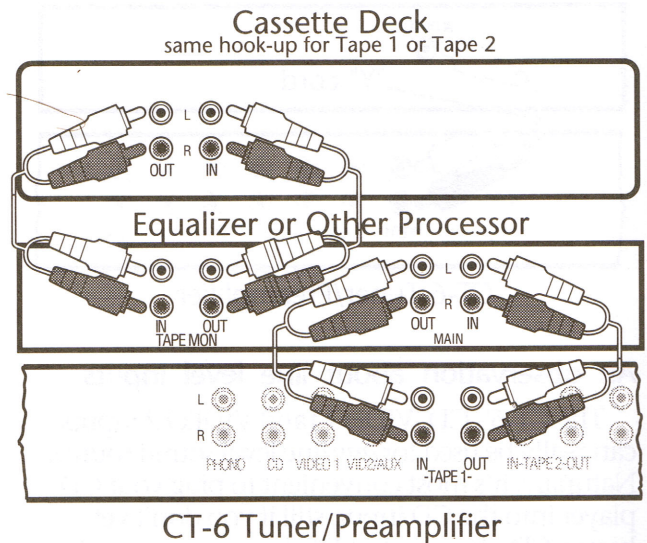

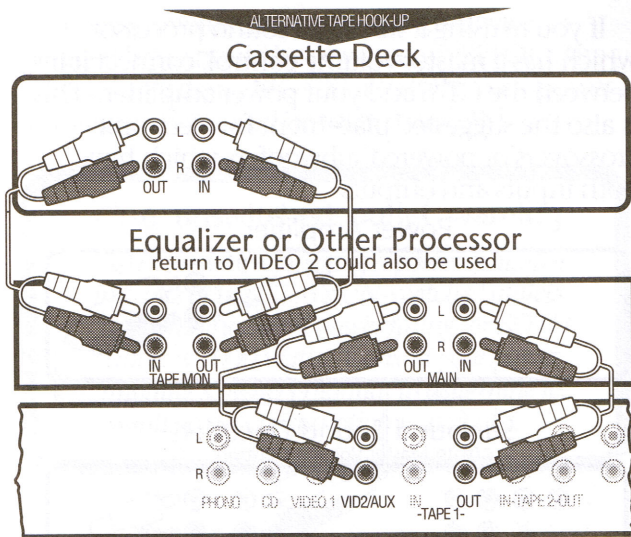

CT-6 Tuner/Preamplifier

Any time the CT-6's TAPE MONITOR button is pressed, the sound from any signal source will be affected by the signal processor. Yet you can still record and play back with the cassette deck.

This is the recommended hook-up for use with leave-them-on-all-the-time components like the speaker control box that comes with a popular brand of "direct reflecting" speakers.

If you have more than one signal processor, for example an equalizer and a dynamic expander, simply "daisy chain" them as shown with the tape deck as the last loop.

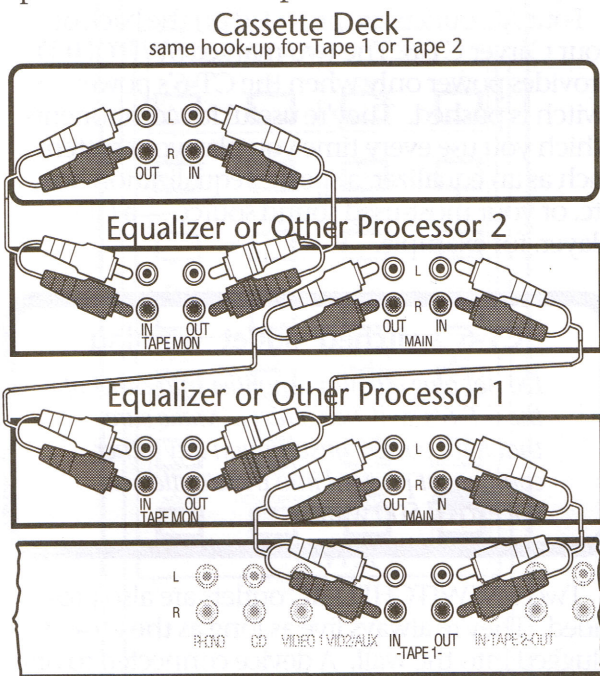

CT-6 Tuner/Preamplifier  
"alternative" hook-up would return MAIN OUTPUT of Processor 1 to CT-6's VIDEO 1 or VIDEO 2

Another possibility is to connect two different processors and cassette decks in separate tape loops. As we'll explain shortly, you can still "process" the sound of any sound source (except tape) through both sound enhancement components. Each individual processor, however, can only affect the tape deck that's in the same loop with it.

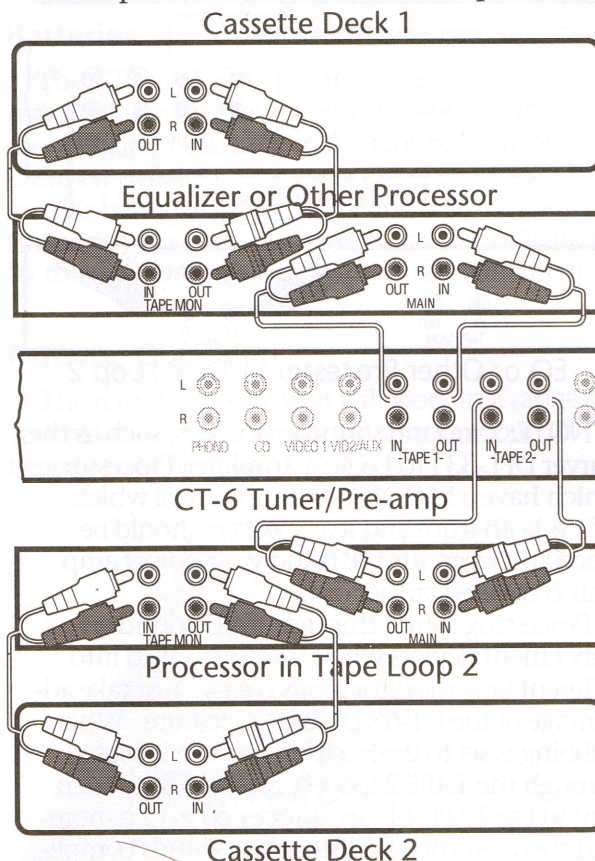

If a signal processor is NOT used in conjunction with cassette deck recording or playback, you have another alternative. This is especially handy for many brands of surround sound decoders which do not have a master volume control. Simply place the decoder in the CT-6's second tape monitor loop.

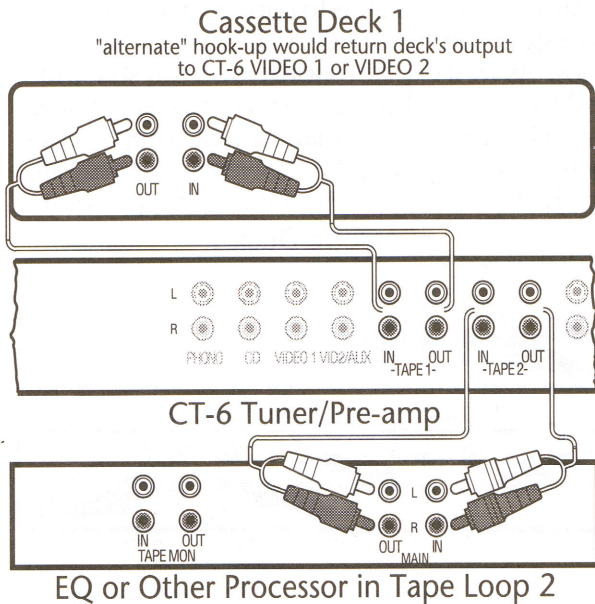

NOTE: Surround sound processors, such as the Carver DPL-33 Pro Logic® Amplifier/Processor, which have a MASTER volume control which affects both front and rear speakers should be placed between the CT-6 and your power amp (this is covered farther on).

Processing sound through TWO sound enhancement devices when they're hooked into different tape monitor loops is easy. Just take advantage of the CT-6's DUBBING feature. When dubbing is set to 2->1, a music source is routed through the TAPE 2 loop, "processed" and then sent to the TAPE 1 loop, "processed" some more and then returned for listening. Sounds complicated and it DOES mean you have to be quite familiar with the CT-6's tape monitor system, but very handy if you like to add "black boxes".

**PRE OUT: Next stop, the power amp**

This is a simple connection. Just connect hook-up cables from the CT-6's PRE OUT to the left and right inputs of your power amplifier.

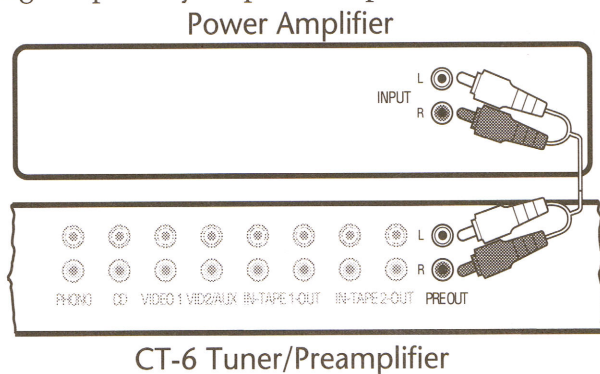

If you're using a surround sound processor which has a master volume control, connect it in-between the CT-6 and your power amplifier. This is also the suggested placement for electronic crossovers or powered subwoofers which have both inputs and outputs.

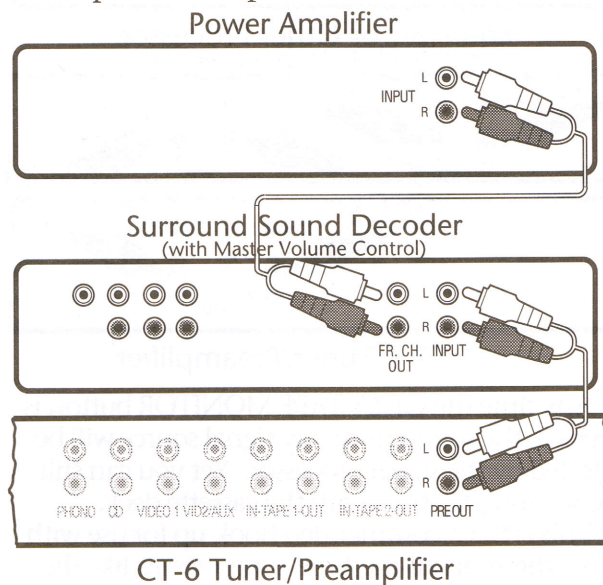

**Convenience outlets**

We cover these last because we don't want to encourage you to plug anything in or turn anything on until all connections have been made.

Four AC outlets are provided on the back of your Carver CT-6. The two marked SWITCHED provides power only when the CT-6's power switch is pushed. They're useful for components which you use every time you play your system such as an equalizer, a speaker equalization box, etc. or your most-used sound source — a CD player, for example.

**CT-6 switched outlet warning**

*Do not plug a power amplifier into either of the CT-6's switched outlets. Make sure that total power consumption any other component plugged into these outlets do not exceed 500 watts.*

Two UNSWITCHED AC outlets are also provided. They're always live as long as the CT-6 is plugged into the wall. A device connected to one of these outlets may be left permanently on, or may be switched off with its own switch. NOTE:

In order to avoid turn-on thumps, a device plugged here should be powered up BEFORE the CT-6 is turned on. **BIG EXCEPTION:** your power amplifier. . . It should be turned on LAST.

### CT-6 unswitched outlet warning

*Take care when plugging a power amplifier into one of the CT-6's UN-switched outlets. The combined total power rating for BOTH outlets is 1000 watts. Consult your power amplifier's owners manual to determine its overall power consumption if in doubt.*

### The final, obvious connection

You guessed it. After making sure that the CT-6 is off, plug its power cord into a wall receptacle.

After a short section on the CT-6's remote control, you'll be ready to start enjoying your Carver tuner/preamplifier!

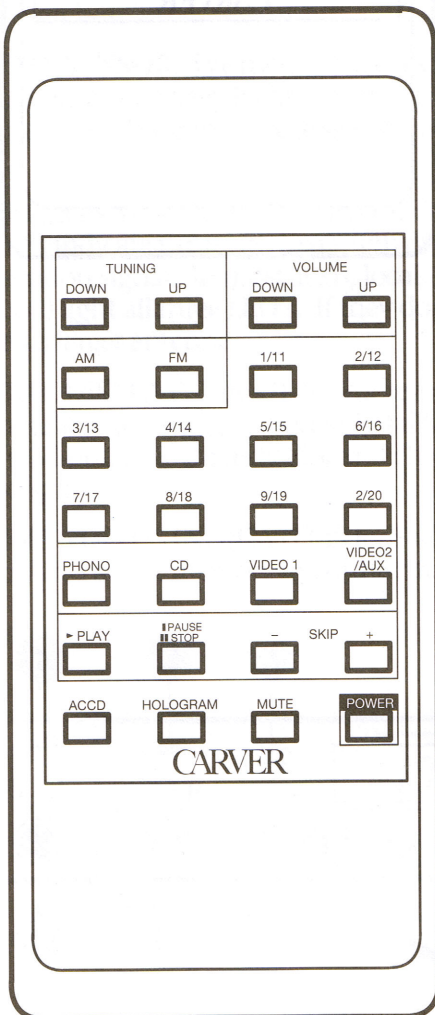

# Remote control

### Batteries

The CT-6's wireless infrared remote requires two AA batteries. Remove the battery compartment door on the back of the remote control by sliding it parallel to the surface of the remote. Insert the batteries supplied making sure to match the positive (+) and negative (-) ends as indicated by the diagram inside the battery compartment.

### Remote Operation

The remote control unit will work in a range of approximately 20 feet in front of and about 30 degrees to either side of the CT-6.

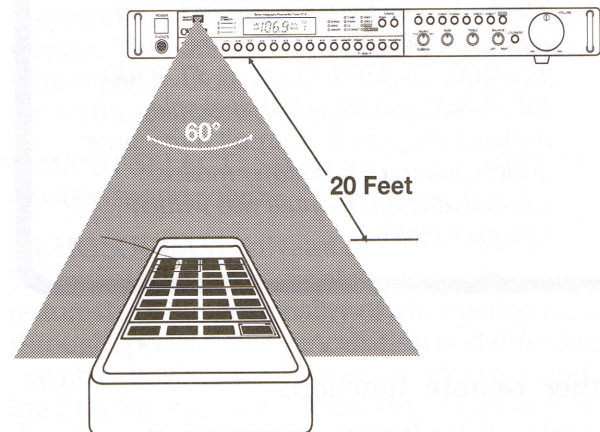

If the remote control begins to occasionally not respond, 1) check its batteries; 2) make sure the infrared projection area on its tip is clean; 3) check that the CT-6 infrared remote sensor square (located directly above the Carver logo on the front panel) is not dirty or blocked from direct line-of-sight contact with the remote.

If you choose not to use the CT-6's remote, put the batteries in it anyway just to try it out once, remove them to prevent corrosion damage. AA cells are not housebroken.

### Remote "differences"

Several EXTRA functions are found on the remote which are NOT found on the CT-6 front panel:

- **MUTE.** When depressed, the MUTE button reduces master volume level by 20dB. Pressing it again restores the previous sound level.

*Bonus nifty feature: Pressing MUTE also changes the inset LED on the CT-6's volume control from green to red so you know the sound is just muted instead of turned down.*

- **CD TRANSPORT CONTROLS**

PLAY  
PAUSE/STOP  
- SKIP  
+ SKIP

#### Remote CD transport compatibility

*The buttons on the CT-6 remote let you control the primary functions of Carver TL-3100, TL-3200, TL-3220, TL-3300, MD/A-420 and SDA-450 single-play compact disc players. Consult your Carver dealer concerning CD player models released after this manual was written (summer 1990).*

### Other remote functions

VOLUME the loudness of the system.

INPUT SELECTIONS include PHONO, CD, VIDEO 1 and VIDEO 2. Note that a tape monitor button has not been included on the remote. If you have a remote control cassette deck and want to remain in your listening position, use the alternate cassette deck hook-up shown earlier in this manual. It routes tape output to one of the VIDEO inputs which IS selectable with the CT-6 remote.

HOLOGRAM activates the CT-6's SONIC HOLOGRAPHY® spacial enhancement feature for the main system only.

POWER fires up the CT-6 and any components connected to its SWITCHED rear panel outlets.

TUNING controls including 10 FM/AM preset buttons, tuning UP & DOWN and AM/FM selection..

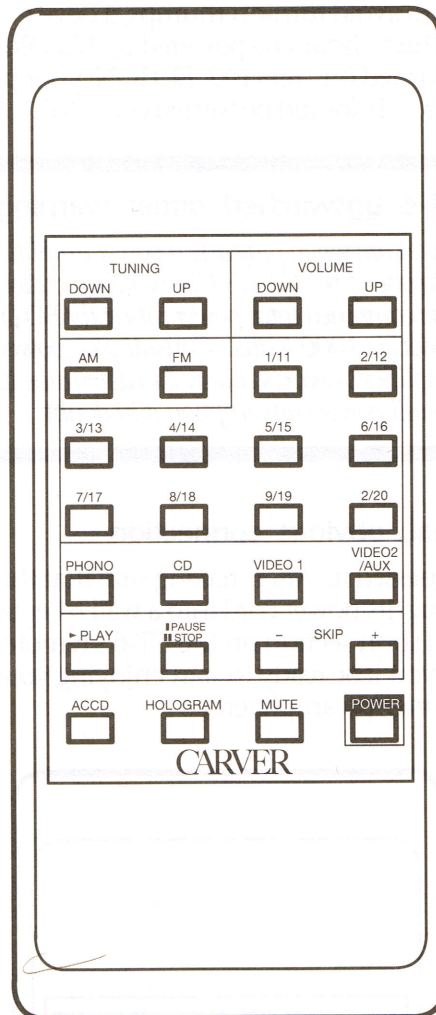

# CT-6 features and functions

It's time for a short guided tour of some of the CT-6's controls and features. If you're eager to listen instead of read, skip to the next section starting on page 18 and read this part later.

**1. POWER.** This is the CT-6's ON/OFF switch. It also affects the two SWITCHED convenience receptacles on the back of the unit. The CT-6 employs an electronic "clammer" to mute the main outputs and headphone output during turn-on and turn-off. This reduces loud transients which could damage a speaker system. This muting system will turn off the signal to your power amplifier. . . 1) for about 3 to 5 seconds after initial power-on, whether by the front panel power switch or from the CT-6 remote; 2) immediately at turn-off, whether by the power switch or by external switches.

**2. REMOTE SENSOR.** We mention it only to note that you should keep it clean so that reception of the CT-6's infrared remote signals isn't blocked.

**3. FM/AM SIGNAL STRENGTH METER.** These three LED's indicate the relative strength of an incoming station signal. In most areas, local stations will light all three LED's. If they don't you may need a larger antenna.

**4. DIGITAL DISPLAY.** The CT-6's fluorescent panel contains the tuning section's digital frequency read-out, FM/AM indicator and channel (preset) display.

**5. TUNING STATUS INDICATORS** for FM stereo, FM mono and preset memory (record) status.

**6. DISPLAY PANEL.** Two rows of LED's show which source has been selected. There are also indicators for ACCD and Sonic Holography®.

**7. UP/DOWN TUNING.** For manual tuning of FM or AM, simply press these UP or DOWN buttons. The CT-6's tuning section will tune up or down and the frequency display will change in small increments which correspond to the possible frequencies which are assigned to FM and AM stations. To locate stations, use AUTO SCAN along with the UP & DOWN buttons. UP/DOWN TUNING is also possible from the CT-6 remote control.

**8. AM & FM SELECTORS.** These select 1) either AM or FM as a sound source and 2) which broadcast band will be received by the CT-6's tuning section. They are also used when programming a station preset. Both have corresponding indicators in the display section of the CT-6.

**9. INPUT SELECT.** Selects the CT-6's external CD or video sound sources.

**10. HOLOGRAM** activates the CT-6's Sonic Hologram Generator. Sonic Holography® can restore the 3-dimensionality of a live performance through special signal cancellation and time delay circuitry. It works with any stereo source including CDs, records, tapes, stereo videotapes and laser discs.

**11. VOLUME.** This is the volume control for your system. It is motorized so that it actually rotates when VOLUME UP or DOWN is pressed

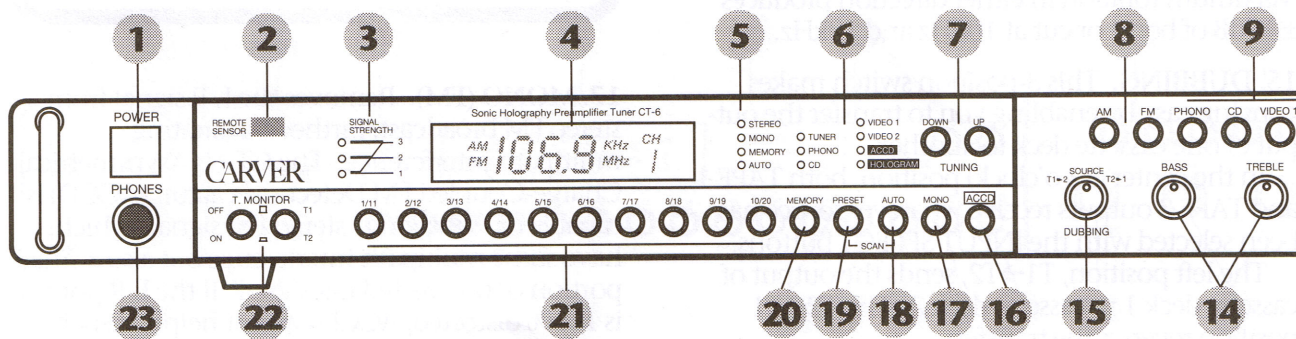



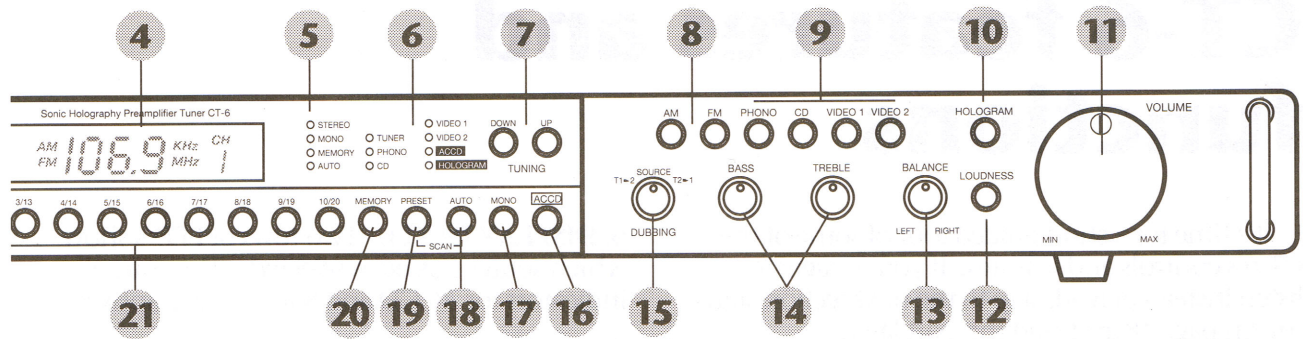

on the CT-6 remote. Do not attempt to manually impede its rotation if someone else is adjusting the volume by remote control.

**12. LOUDNESS** is a special equalization circuit designed for improved sound at low, “background” listening levels. Due to certain characteristics of the human ear, we’re more sensitive to midrange sounds at low volume levels than we are to high and low frequencies. The loudness circuit compensates for this by boosting high and low frequencies, creating a more balanced sound at low to moderate “background music” levels.

**13. BALANCE CONTROL.** Adjusts the left/right distribution of sound to your speakers. It is useful when one speaker is closer to your listening position than the other, or with some poorly recorded material which has more of one channel than the other. The sweep of the CT-6’s BALANCE control is intentionally not linear. That is, small movements off center produce smaller shifts in the stereo image per degree of rotation than near the extreme left and right positions. This makes slight adjustments more convenient..

**14. TREBLE and BASS** tone controls. Two “shelving-type” tone controls are provided for general sound shaping. The BASS control is effective below 1000 Hz; treble above 1000 Hz. At their center detent position, there is no boost or cut. Maximum rotation in either direction produces  $\pm 10$ dB of boost or cut at 100Hz and 10kHz.

**15. DUBBING.** This 3-position switch makes copying easy by enabling you to transfer the output of one cassette deck to another.

In the center (12 o’clock) position, both TAPE 1 and TAPE 2 outputs receive whatever source has been selected with the INPUT SELECT buttons.

The left position, T1→T2, sends the output of cassette deck 1 to cassette deck 2. The T2→T1 position reverses the transfer.

**16. ACCD.** The Asymmetrical Charge-Coupled FM Detector is a patented circuit incorporated into the CT-6. Because FM stereo transmission is inherently prone to multipath interference, even the most “advanced” conventional tuner circuitry is forced to deal with a potentially flawed signal. Only Carver ACCD Tuner Circuitry is capable of restoring — literally transforming a multipath-ridden FM station into a clean, clear signal. It separates the FM signal’s stereo (L-R) and mono (L+R) components, rejecting up to 80% of the fragile, distortion-filled stereo signal. The 15-20% of the signal which is “clean” is used to accurately recreate the rest of the stereo signal. You hear clean, clear FM with accurate frequency response, wide dynamics and ambient stereo information.. even when a high portion of the L-R (stereo) FM signal is being ravaged by multipath. ACCD has a corresponding LED indicator in the display section of the CT-6.

### Speaker placement for Sonic Holography® is critical

*For maximum effect, the CT-6’s Sonic Holography® sound processing system requires careful set-up and adjustment of your speakers. Please consult the SONIC HOLOGRAPHY section beginning on page 21 of this manual before experimenting with the HOLOGRAM button.*

**17. MONO (FM).** Removes the L-R signal from a stereo FM broadcast, further eliminating multipath interference. The CT-6’s Asymmetrical Charge-Coupled FM Detection Circuit (ACCD) is capable of “salvaging” stereo FM signals which have some multipath interference but also a small portion of unaffected L-R signal. If the L-R portion is 100% distorted, ACCD cannot help. At such

times, the signal may be switched to mono by pushing this button.

NOTE: The CT-6 MONO button does not affect other input signals such as records or CD's. MONO has a corresponding LED indicator in the display section of the CT-6.

**18. PRESET SCAN.** lets you "sample" a 5-second segment of each station preset.

Press PRESET SCAN to hear a short segment of each consecutive preset. This preview will continue through each assigned presets until you choose to stop it. When you have found a station you want to keep listening to, press PRESET SCAN again. The scan process will stop and the CT-6 tuning section will remain on the preset which has been selected.

### AUTO SCAN

*AUTO SCAN works in conjunction with the CT-6's UP and DOWN tuning buttons. Simply pressing AUTO SCAN button "toggles" between AUTO and MANUAL tuning modes.*

*If AUTO SCAN is in operation when the CT-6 is turned off, the scanning process will continue when the tuner/preamplifier is turned on again – even if it's been unplugged for several days!*

**19. AUTO SCAN.** In conjunction with the UP & DOWN TUNING buttons, this automatic feature seeks and stops at every AM or FM station which is strong enough to light at least the first two LED's of the CT-6's LED tuning display.

First press AUTO SCAN. Then press TUNING (UP or DOWN). Scanning will begin at the fre-

quency at which the tuner is currently set and "seek" in either direction until it encounters a strong station. It then stops to let you hear the station. To continue the scanning process, press AUTO SCAN a second time. The scanning process will continue to the "end" of the FM or AM frequency band and then continue from its opposite "end".

**20. MEMORY.** This button is used to record station presets. Instructions for its use begin on page 19. Memory has a corresponding LED indicator on the CT-6 front panel.

**21. FM/AM PRESET BUTTONS.** The CT-6 lets you preset up to 20 different AM and FM stations in any combination. Each of ten buttons are numbered with two different presets: For example, 4 and 14. Once stations are entered into memory, pressing a button once quickly calls up the lower numbered preset (Number 4 in our example). Holding the button down longer calls the second, higher numbered presets (Number 14 in our example). You may use as few or as many of the presets as you choose. Both presets on a single button need not be used. All 20 presets may also be recalled from the CT-6's remote control.

**22. T. MONITOR.**

### TAPE MONITOR

*The CT-6 uses an approach to selecting either of its two tape monitor loops that differs from many other models. There are two tape monitor buttons, but they are **not** labeled 1 & 2 as you might expect. Instead, one button selects TAPE as the music source and the other determines **which** tape monitor loop will be selected.*

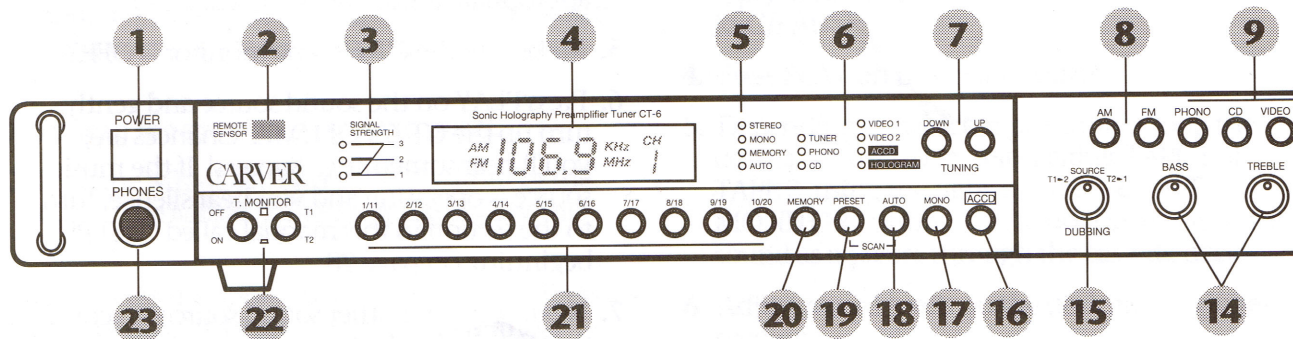

**OFF/ON**, the left-hand T. MONITOR button, is used to activate BOTH tape monitor loops.

**T1/T2**, the right button, chooses which tape input you wish to listen to.

Naturally, the T1/T2 button has no effect unless the OFF/ON button is in the ON position.

For example, to select a cassette deck connected to TAPE 2, you would first press the ON/OFF tape monitor button (selects a tape monitor loop as the playback source when ON), and then press the T1/T2 button (selecting TAPE 2).

**23. HEADPHONE jack.** All conventional dynamic headphones may be plugged in here. Headphone impedance may be from a few ohms to several thousand ohms, although output level may vary depending on impedance. The headphone jack is driven by a separate internal amplifier, designed to provide the extra voltage and current gain needed. The signals present at the headphone jack are identical to those at the CT-6's PRE OUT output.

When you plug in headphones, the output to your main system speakers is muted. It is recommended that headphones be unplugged from the CT-6 when not being used to avoid risk of damage to them at high volume settings.

Step-by-step instructions for tape operations are in the next section.

If patience has prevailed and you have read this whole section BEFORE playing with your CT-6, we congratulate you. Now for the fun part!

# Enjoying your CT-6

If you have experience with serious stereo components, you probably won't need to read this section — assuming, of course, that you've read the previous section (CT-6 Functions and Features). But for the rest of us who only change stereo systems every decade or so, we've included step-by-step instructions for frequently-used functions. Don't be embarrassed to read through them. Besides, we've suggested some "alternate" hook-ups which would require you to depart from common procedures.

## A short test drive

Because the CT-6 is essentially the nerve center of your stereo system, lots of stuff has been connected to it, in fact, every other stereo component you own. So it's a good idea to double-check and confirm your work up to this point.

1. Check all connections, first to confirm the right components are plugged in to the appropriate CT-6 inputs. Then make sure lefts are connected to lefts, etc.
2. Turn the CT-6 VOLUME control down to MIN.
3. Now turn on your system in the following order:
  - A. Any components not connected to the CT-6's SWITCHED outlets.
  - B. The CT-6.
  - C. Your power amplifier.
4. Load one of your favorite songs on the CD player or turntable, and then select the appropriate input button on the CT-6.
5. Make sure the CT-6's tape monitor is OFF.
6. Press PLAY on the sound source and gently turn up the CT-6 VOLUME. Chances are, you'll hear something. Success! If the music source is operating and you hear silence, turn to the section in this manual called "HELP!" beginning on page 28.
7. Next, play your other sound sources to confirm that they're hooked up properly.

8. Rotate the balance control and see if the sound moves in the correct direction. If it seems to move the opposite way, your speaker-to-amp or CT-6-to-power amp connections have been reversed and need to be switched. If the CT-6 is part of a completely new system, you should check speaker phasing as well (covered in our Magnetic Field Amplifier manuals).

---

### Tuning an FM or AM station.

1. Turn on the CT-6 and the power amplifier.
2. Make sure that the appropriate antenna is connected to the CT-6.
3. Select TUNER from the input source buttons.
4. Select AM or FM by pressing the appropriate button.
5. Advance the CT-6's volume control about 1/4 of the way.
6. Either press TUNING UP or DOWN to manually tune a station, or press AUTO SCAN until the AUTO LED lights and then press TUNING UP or DOWN until the desired station is reached.

---

### Setting FM/AM station presets.

Your Carver CT-6 can memorize and recall up to 20 FM and AM stations in any order. Note that you may devote as many of the 20 presets to FM as you like (not just the first 10). For example, you could have 17 FM stations and 3 AM stations preset. Our only suggestion is that you put your station presets in order of how often you listen to the station. That way when you hit PRESET SCAN, you'll be previewing favorite stations first.

The memory inside the CT-6 will retain preset information for about 3 days after it is disconnected. This helps prevent information loss when moving your system around or from power outages.

1. Tune in the station you want to preset.
2. Press the MEMORY button on the front of the CT-6. The MEMORY LED on the display will light up.
3. Now press the appropriate preset button. Press it once quickly to set a lower preset number (1-10). To enter presets 11-20, hold the

corresponding preset button down for several seconds until the higher number appears in the numeric display. The station has now been entered into the CT-6's memory.

4. Repeat Steps 1-3 for up to 19 more stations.

NOTE: If a station was already entered into a given preset, it will be erased if you choose the same preset number for a new station.

---

### Playing a tape

1. Turn on the cassette deck, CT-6, and power amplifier.
2. Press the TAPE MONITOR ON/OFF button in the ON position (or VIDEO 1 or VIDEO 2 if the alternate hook-up has been used).
3. Depending on which tape monitor loop the deck is connected to, select either TAPE 1 or TAPE 2.
4. After loading a tape you KNOW has music on it, press PLAY on the cassette deck.
5. Adjust the CT-6's volume control or press DOWN or UP on the remote control.

---

### Recording a tape ("conventional" tape hook-up)

1. Select the source which has the original from which you wish to record by pushing one of the input buttons.
2. Press the TAPE MONITOR ON/OFF button in (the ON position).
3. After loading a blank cassette into the deck and making any necessary adjustments for tape type, noise reduction, etc., put the deck into REC/PAUSE.
4. Press PLAY on the sound source.
5. Depending on which tape monitor loop the deck is connected to, select either TAPE 1 or TAPE 2, using the right-hand CT-6 TAPE MONITOR button. You're now listening to the sound as it passes through the cassette deck.
6. Adjust record levels on the deck and begin recording.

- To hear the source, set the TAPE MONITOR ON/OFF to OFF (out). To hear the output from the deck, turn the CT-6's tape monitor ON.

### Recording a tape ("alternate" tape hook-up — see page 11)

If you've connected your deck so that you can select it as an input by remote control, it is not necessary to use either of the TAPE MONITOR buttons.

- Select the source which has the original from which you wish to record by pushing one of the input buttons.
- After loading a blank cassette into the deck and making any necessary adjustments for tape type, noise reduction, etc., put the deck into REC/PAUSE.
- Adjust record levels on the deck and begin recording.

NOTE: Don't attempt to monitor the tape deck output during recording by selecting VIDEO 1/2. To do so will disable the input you're recording from.

### Copying a tape from Deck 1 to Deck 2 ("conventional" hook-up)

- After turning on the CT-6, power amp and both cassette decks, press the CT-6's TAPE MONITOR ON/OFF button.
- Using the TAPE MONITOR T1/T2 button, select the deck which is doing the recording. We'll refer to it as the target deck.
- Turn the CT-6's DUBBING knob to either T1→T2 or T2→T1. The arrow points from the source deck to the target deck.
- Start the playback deck and put the target (recording deck) into REC/PAUSE. You should now hear the output of the source deck as it arrives at the target deck. Adjust recording levels on the target deck.
- Begin recording onto the target deck.
- To monitor the source tape, release the CT-6's T1/T2 button back to it's OUT (Tape 1) posi-

tion. Do NOT select SOURCE on the 3-position DUBBING knob.

- If your two cassette decks differ in quality, it is general practice to use the better deck as the target deck.
- If the source tape is Dolby® B or C NR encoded, activate that type of noise reduction on the source deck. The tape will then be "decoded" before it is sent to the target deck. If you want the copy to include either Dolby B or C noise reduction, select it on the target deck. The reason for this encode/decode process is because Dolby noise reduction is quite sensitive to variations in a deck's high-frequency record and playback capabilities. If you transfer music "straight", i.e. still noise encoded, the target deck may not be able to correctly play back, resulting in a reduction or exaggeration of high frequencies. By removing the noise reduction and then adding it again, you ensure getting the best quality copy.

### Copying a tape from Deck 1 to Deck 2 ("alternate" hook-up)

- After turning on the CT-6, power amp and both cassette decks, press the CT-6 input button that corresponds with the source deck (most likely VIDEO 2).
- Start the playback (source) deck and put the target (recording deck) into REC/PAUSE. Its meters should be reacting to the playback of the source deck. Adjust recording levels on the target deck.
- Begin recording onto the target deck.
- Unfortunately, it is not possible to monitor the target deck's output during playback when using the "alternative" hook-up. To do so would require changing the input. This set of buttons must remain selected to the source deck for the duration of the copy process.

---

### Signal processors and cassette deck record/playback

You may have hooked a signal processor into one of the CT-6's tape monitor loops and then connected your tape deck to that component's tape loop. If so, make sure that the signal processor's TAPE MONITOR button is pushed before operating your deck. The signal processor component is invisible to the recording/playback process (unless it has an EQ TAPE recording function). But it has to be turned ON, and its TAPE MONITOR button must be pushed in.

---

### Enhancing a video soundtrack with a surround sound decoder

If you took our advice and have connected your Dolby® processor (one which does not have a master volume control) in the TAPE 2 monitor loop, you can activate this component by pressing TAPE ON/OFF and putting the T1/T2 switch in the T2 position.

Select the appropriate VIDEO source on the CT-6's INPUT SELECT section and the VCR or LaserDisc's audio will be sent to the decoder.

### Cleaning

You'll want to wipe off the CT-6's front panel and chassis from time-to-time with a soft, dry cloth. If you have something stubborn to remove, use a mild dish soap or detergent sparingly applied to a soft cloth; don't use alcohol, ammonia, or other strong solvents.

# Enjoying Sonic Holography®

## Sonic Holography® is extremely dependent on speaker placement

*After installing and connecting the CT-6 to the rest of your stereo system, you'll probably be tempted to begin playing music and experimenting with Sonic Holography®. We urge you to resist this temptation for the moment. If you decide to try it anyway, not much will happen. . . because you're only part way there. Successful Sonic Holography® depends on proper loud-speaker placement and other important factors. Read the following section and follow the instructions and recommendations exactly.*

### It's worth the effort

Making Sonic Holography® work properly requires attention to many factors that usually aren't problems or considerations for normal stereo playback.

The two most important factors are 1) accurate relationships between the loudspeakers and listening chair, and 2) dealing with reflected sound off surfaces in the listening room.

The real key to this process are the relationships between the loudspeakers and chair. While minimizing room reflections is almost as important, a musical image in Sonic Holography® will never fully occur unless the correct, accurate loud-speaker/listening chair relationship is achieved.

This whole process might seem impractical, or a lot of trouble and effort, but you'll be amply rewarded by the stunningly live imaging that Sonic Holography® brings to your favorite music.

Sonic Holography®

**Room examples**

The first two sample rooms show the loudspeakers and listening chair in perfect positions for Sonic Holography®. But, as we've mentioned, it may not be practical to place them there. It's your mission (should you accept it) to find a point where adjustments for successful Sonic Holography® can co-exist happily with the aesthetic considerations of room decor. Look at the diagram of Room A:

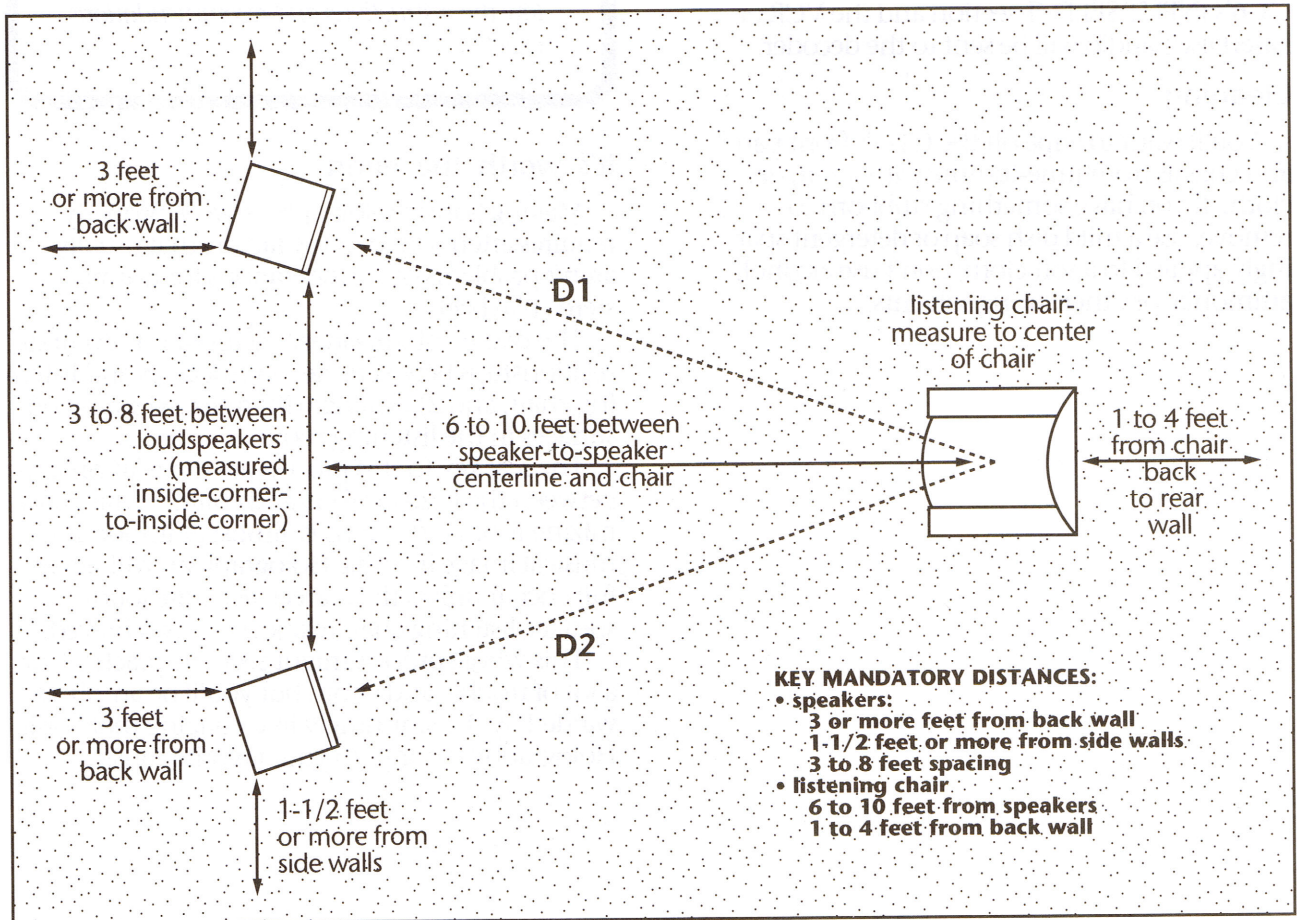
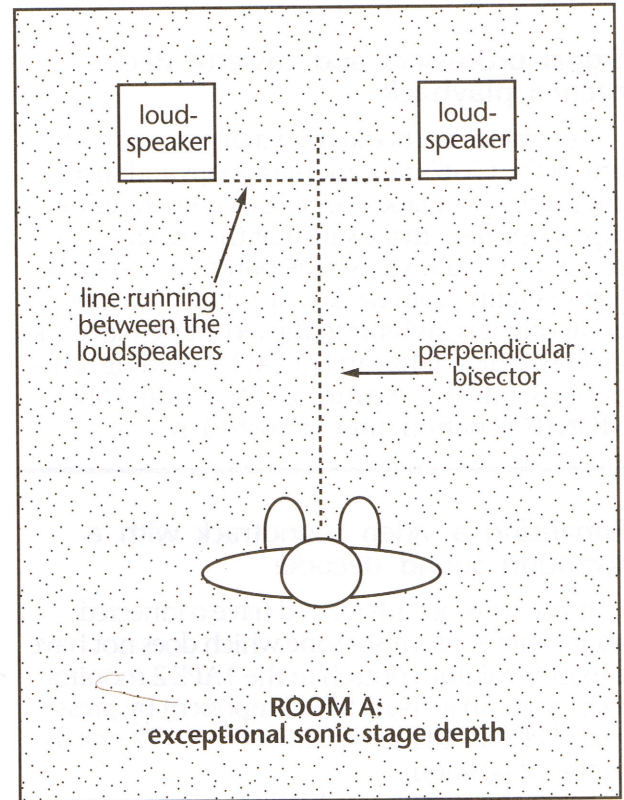

Here the loudspeakers project the long throw of the room, yielding a large front-to-back depth of the sonic stage.

Room B, where the loudspeakers project the short span of the room, has exceptional sonic stage width and moderate front-to-back depth. Naturally the choice of positioning depends on your personal taste, as well as furnishings and overall room arrangement.

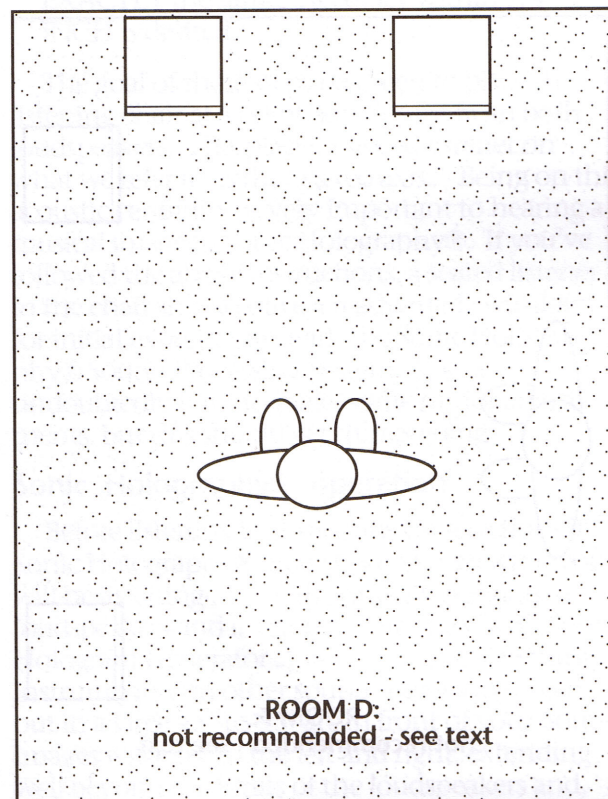
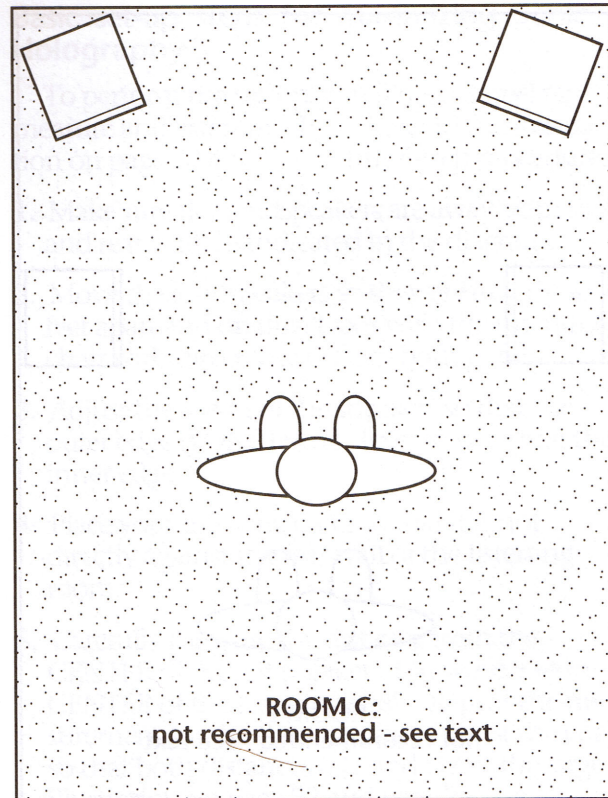
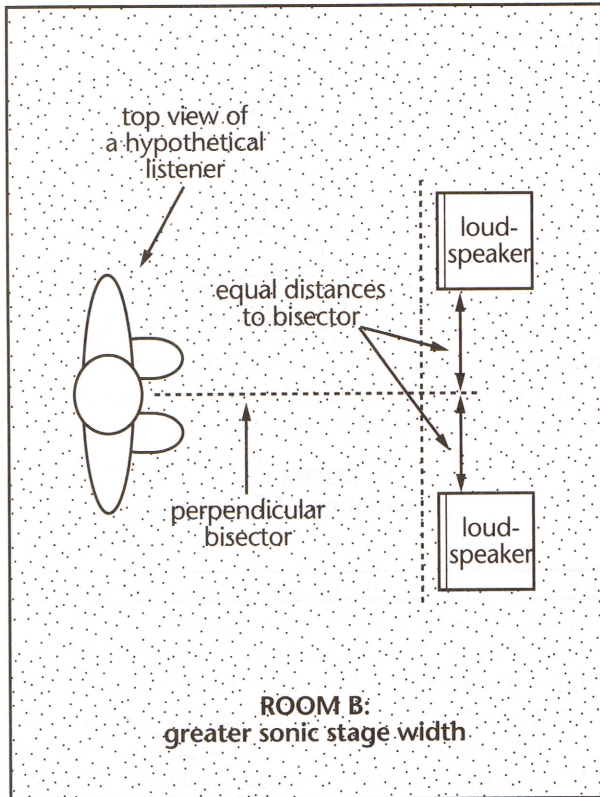

Sample Rooms C, D, E and F show configurations that won't work well with Sonic Holography®, though these same set-ups are often quite acceptable for conventional stereo playback. Other than poor loudspeaker placement, side/boundary-wall reflections will destroy chances of a good holographic image taking form.



Better room arrangements are illustrated in Rooms G and H.

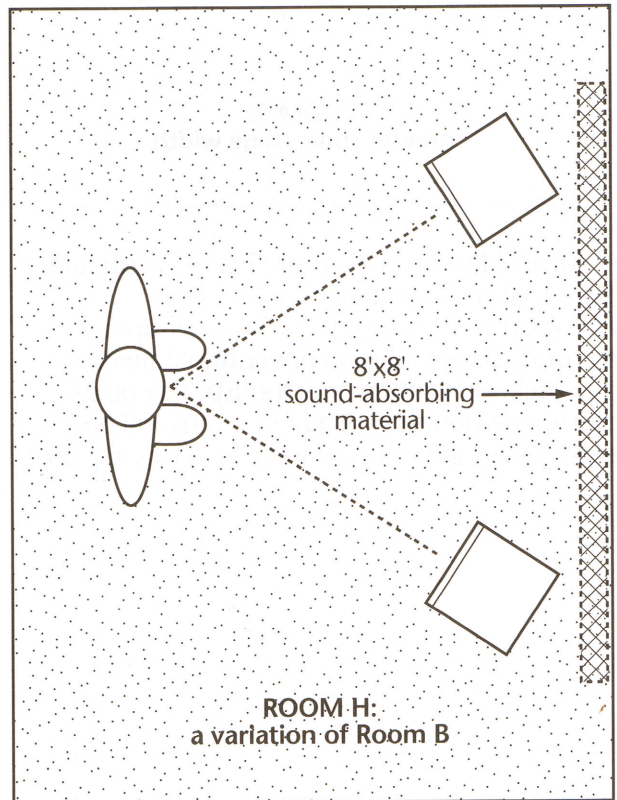
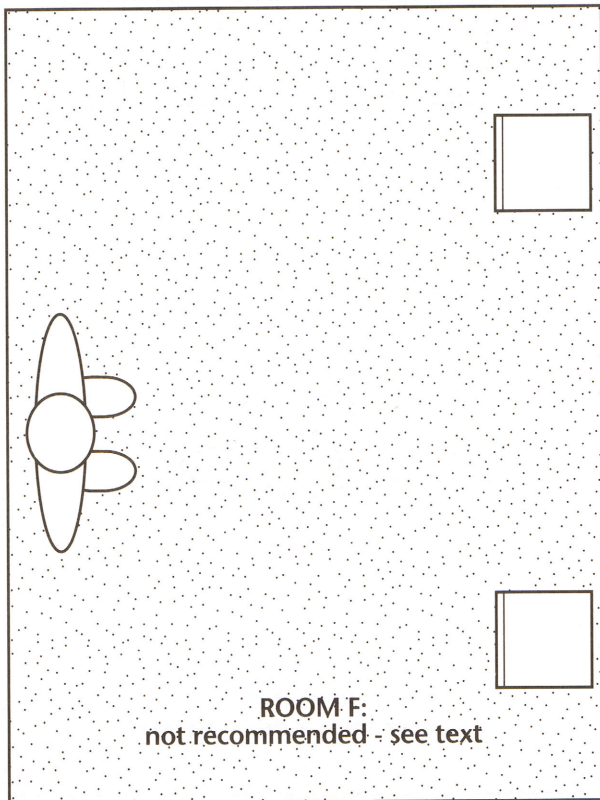
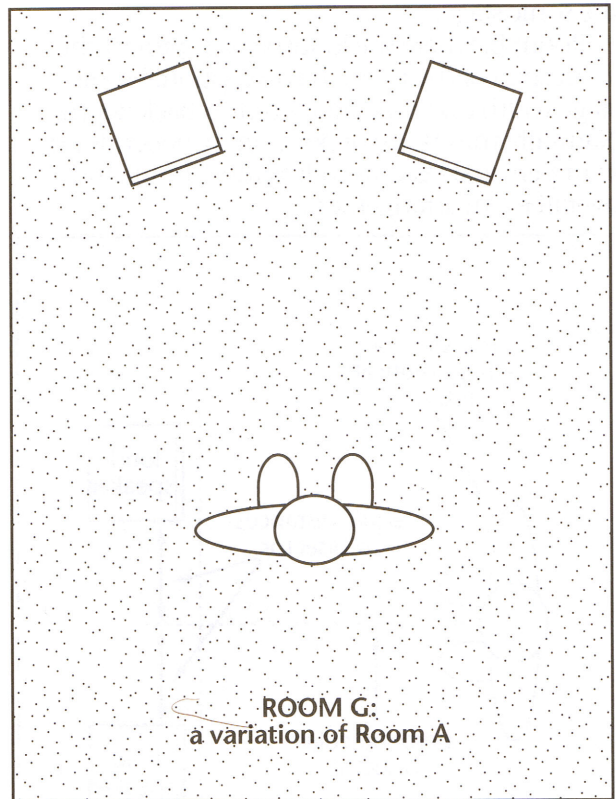
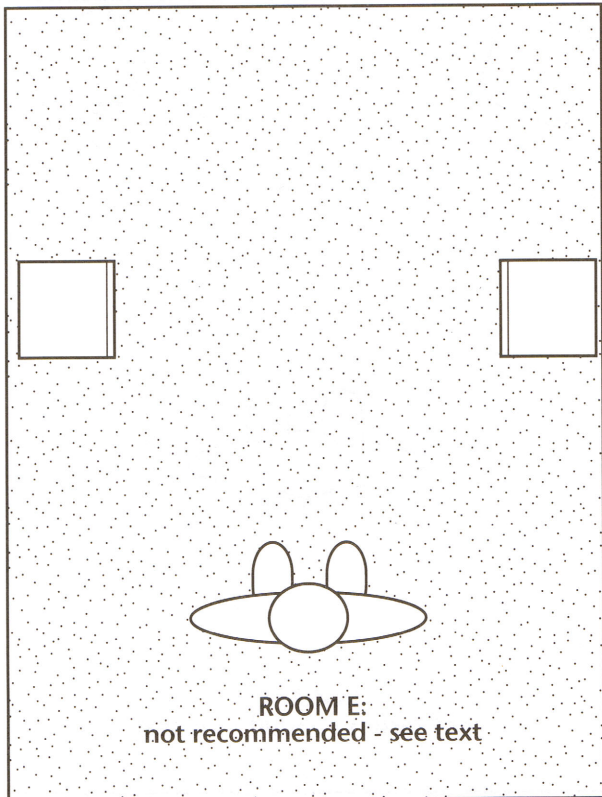

Room H uses a “trick” to get the loudspeakers almost against the wall behind them. This consists of a sound-deadening panel placed behind the loudspeakers, right against the wall. We’ll come back to Room H in a moment.

Refer again to the diagram of Room B which compares favorably to both Rooms G and H. What makes it so good for Sonic Holography®? First, as in the initial set-up, the loudspeakers are away from corners, side walls, and the wall behind the loudspeakers. The listener is seated with a reflective wall about one to four feet behind them. This places the listener in a sound field made up of direct sound from the loudspeakers and reflected sound from the rear wall.

In Room G, with the loudspeakers still away from the side walls and corners, the listener has a nearby rear wall to ensure front-to-back depth in the holographic image. As in any good placement for Sonic Holography®, the loudspeakers are toed-in toward the listening chair. This places the listener on-axis with direct sound from the loudspeakers, further reducing side-wall reflections at the same time.

### Loudspeaker designs and early reflections

The CT-6’s Sonic Holography® Sound Processing System uses signal delays of a fraction of a millisecond. In some loudspeakers, reflections with similar delays can be caused by protruding edge moldings, grillwork, or other front surface irregularities that might dilute an image when the CT-6’s Sonic Holography® feature is engaged.

Most modern loudspeakers use sound-absorbing materials, rounded corners, or even unconventional designs to reduce these early reflections. In all fairness, most loudspeakers with “conventional” front panels won’t have any serious reflection problems that could hurt or weaken holographic images. However, if sound images remain fuzzy and unresolved, even with close attention to all other factors, there’s a possibility it could be the result of early reflection off front-panel irregularities.

The solution to this problem consists of placing a cut-out of acoustic felt around the various elements in your loudspeakers.

### Basic set-up steps for maximizing Sonic Holography®

To perform the set-up, you’ll need a steel tape measure and listening chair. Refer to the illustration on page 22 and follow this 5-step procedure:

1. Make sure the loudspeakers are away from side and rear walls as indicated in the diagram.
2. Move the loudspeakers so they are exactly six feet apart and on direct axis with the listening chair with direct sound from both panels.
3. Adjust the toe-in of the speakers so that the outer edge is ONE INCH closer to you than the inner edge.
4. Place your listening chair so that it is not directly against the rear wall of the listening room.
5. Carefully measure the distance from the CENTER of the left speaker’s top woofer to the CENTER of the listening chair. Repeat the measurement for the right speaker. Adjust the chair so that both distances (D1 and D2 in the large illustration on page 22 and page 28) are EXACTLY the same. Accuracy within 1/4 INCH is desired.

The goal of these steps has been to place the listening chair at a point equidistant from both loudspeakers. This places a seated listener on what we refer to as the “stereo axis.” Being on this acoustic centerline is very important to hearing a musical image in Sonic Holography®. If you’ve followed the above instructions, a seated listener in the chair should have a ready-made window for initial experiments with the Sonic Holography® Sound Processing System. You’ll undoubtedly have to make some minor adjustments, but this should get things going.

### Sonic Holography® operation

Before listening to some musical selections in Sonic Holography®, you should know what you will be listening for. With correctly positioned loudspeakers and listening chair, the CT-6’s Sonic Hologram Generator system should cause musical instruments and other sound sources to spread out in a large 45°-to-95° arc in front of you. Sound images will exist to the left and right, extending well beyond the limits of the loudspeakers and, occasionally, all the way to the extreme left and right.

You'll be able to perceive a sonic stage depth of 10 to 20 feet with sound images clearly floating behind and, from time-to-time, in front of the loudspeakers. You can actually turn your head and look at the sound images; these images will seem to stay put in space. Some sound images may even seem to clearly emerge from outside the walls of the listening room.

### A "test flight"

If you've correctly established the initial relationship between the loudspeakers and listening chair, you should be able to experience Sonic Holography® at this point.

First, take a couple of minutes to "preflight check" your stereo system:

1. Visually check out and confirm that all components are connected in phase (all left-channel outputs to left-channel inputs, right-channel outputs to right-channel inputs).
2. Check and confirm that the loudspeakers are properly wired in-phase (positive "+" speaker terminals on the amplifier or receiver should be connected to the positive terminals on the loudspeakers; negative "-" outputs to negative terminals on the loudspeakers).
3. If your system employs an external equalizer to flatten room response, we recommend that you switch it out of the CT-6 signal path. Wait until you've had a chance to experience and experiment with Sonic Holography® before re-equalizing the room. Room response will also be altered by any sound treatments used to reduce room reflections, so wait until all phases of the Sonic Holography® set-up are complete to save time and trouble.
4. If you are using a record for a sound source, inspect the phono stylus and cartridge for proper phasing, wear, and tracking. A cartridge/stylus in poor shape can upset the balance of the program material before it gets to the rest of the stereo system. This can simulate certain acoustic problems that cause strong one-side imaging with weak imaging on the other.

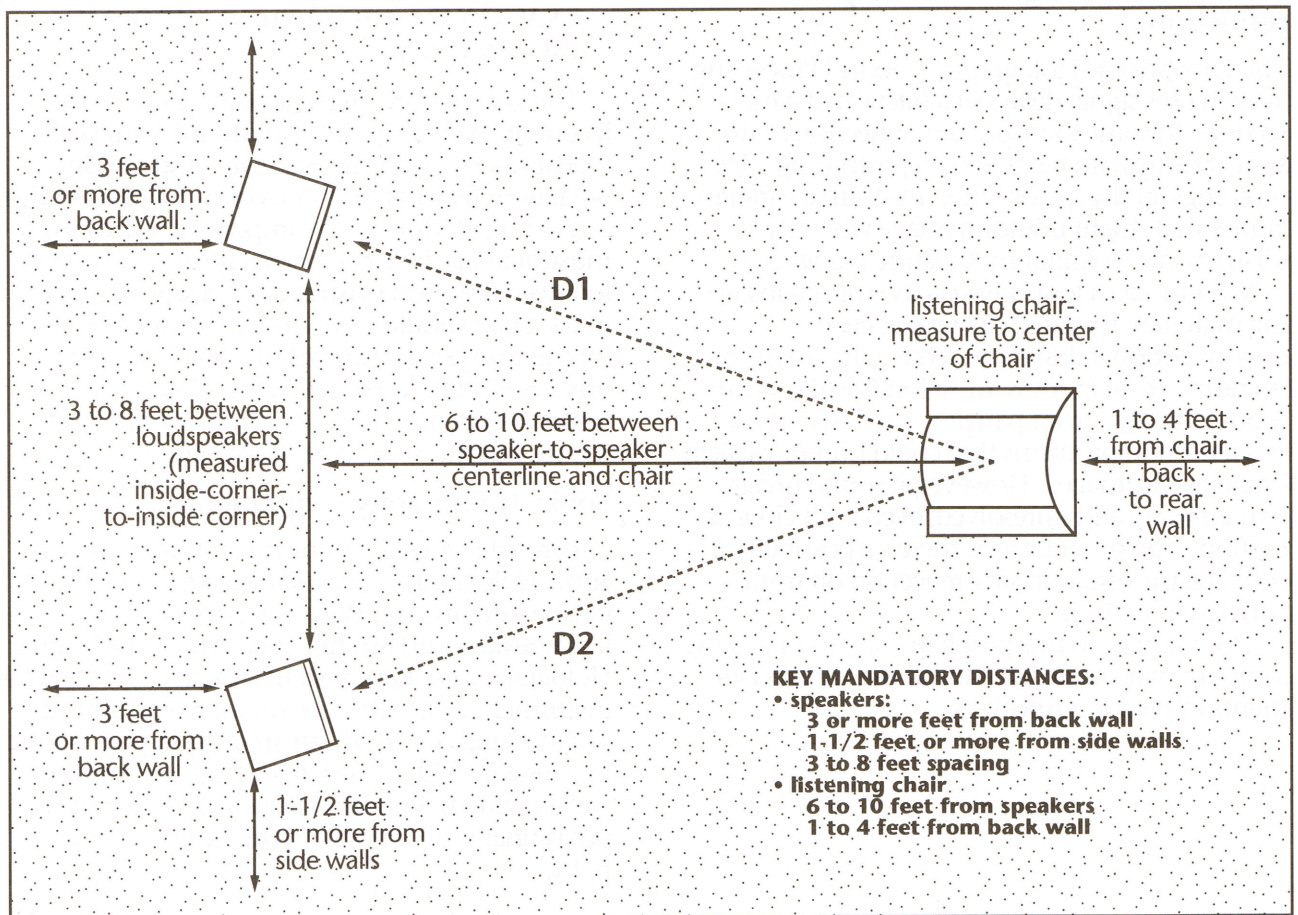

5. Set the CT-6's BALANCE control to "center." Set the BASS and TREBLE tone controls to their center (12 o'clock) position.
6. Press the CT-6's HOLOGRAM button.
7. Play a stereo recording with only a few instruments and the human voice for first-time attempts at Sonic Holography®.

You should now hear Sonic Holography® in action.

### Sonic Holography® fine tuning

Carefully adjusting the following parameters will result in the best possible Holographic image:

1. Tilt-back angle and toe-in angles.
2. Distance of speakers and listening chairs from back wall.
3. Room reflections.

**TILT-BACK AND TOE-IN ANGLES.** If you are in a seated position, decreasing the tilt-back angle of most typical speakers will result in more high frequency and less midrange energy at your listening position. It will also lower the soundstage closer to the ground. If you are in a standing position, these effects are reversed. Decreasing the tilt will result in less high frequency energy and will bring the midrange slightly forward.

It is possible to find a tilt-back angle that will allow the tonal balance to remain unchanged from sitting to standing. This specific angle may or may not result in the preferred tonal balance. We recommend that you determine your favorite tilt-back angle while seated. But remember, changing the tilt angle will also change the height of the sonic image. The less tilt, the lower the image. Increasing the tilt angle will, however, often enhance the dimensionality of the soundstage.

Toe-in (the lateral angle of the speakers) also affects Sonic Holography®. When experimenting with speaker angle, make sure that the speakers are equally toed in. This can be done by measuring the distance from the inner and outer corners to the back wall of the listening room.

**DISTANCE FROM BACK WALL.** The purpose of keeping the loudspeakers away from the walls is to provide a direct, speaker-to-ear sound path with a minimum of extra, unwanted reflections off surfaces in the room. Just as the second-sound arrivals confuse the ear in normal stereo playback, early arrivals of reflected sound can further con-

fuse the issue and ruin attempts at creating holographic images. Always keep in mind the importance of accurate loudspeaker/listening chair relationships, keeping the loudspeakers relatively close together (three to five feet, center-to-center).

**ROOM REFLECTIONS.** For the best possible Sonic Hologram generation, the area around and behind your speakers should be relatively dead. If the back and side walls are too reflective, they may generate additional sound reflections which can interfere with Sonic Holography®.

The object of acoustically treating the listening room is to create what's known as a "live end/dead end" configuration. This design makes the area around the loudspeakers acoustically "dead," while the area around the listener is kept "live." Thus random sound reflections reach a listener long after the direct sound, establishing a uniform sound field.

The reflections most in need of correction in your listening room are the usually strong, side-wall reflections that originate from surfaces near each loudspeaker.

Any treatment should be applied to the wall extending two feet above and below the midrange and high-frequency loudspeaker elements, standing two to three feet from the leading edge of the loudspeaker cabinet.

The treatment itself may be quite simple. Open, full book cases or record shelves, heavy fabric hangings, or draperies made of heavy material will work well as an acoustic treatment for many situations. Sound panels made from cork or acoustical tile can be covered with a variety of other sound-absorbing materials, too.

Since side-wall sound treatments are relatively small (usually less than four feet by four feet), you could use attractive grill cloths or foam panels to improve the appearance. However, loudspeaker grill cloths or covers are not, obviously, effective sound absorbers. Scrap carpeting can be effective when used with other sound-absorbing materials.

**Patent Notice (our lawyer insists. . .)**

The circuitry and application of the CARVER Sonic Holography® Sound Processing System are protected by United States Patent 4,218,585 and corresponding foreign patents.

**Dolby Notice (their lawyers insist. . .)**

Dolby and Pro Logic are trademarks of Dolby Licensing Corporation.

©1990 All rights reserved,  
CARVER CORPORATION P.O. Box 1237,  
Lynnwood, WA 98046 (206) 775-1202.  
Pub# 900703-A  
Written and produced in America

PRINTED IN JAPAN

9

# CARVER

# CARVER

## CARVER CORPORATION LIMITED WARRANTY HOME AUDIO PRODUCTS

### Product

### Warranty Period

Amplifiers, Pre-Amplifiers, Sonic Hologram Generator, Speaker Control Boxes ..... 3 years  
Receivers, Tuners, Integrated Amplifiers, Pre-amp/Tuners, Selector Boxes ..... 2 years  
Video and Compact Disc Players and Changers, Cassette Tape Decks, Remote Controls,  
In Wall Remote Sensors and Transmitters and Other Accessories ..... 1 year

**YOU MUST RETAIN AND PROVIDE YOUR SALES RECEIPT TO OBTAIN COVERAGE UNDER THIS LIMITED WARRANTY.** The Warranty Period begins from the date of first consumer purchase from an Authorized Carver Dealer.

**WHAT IS COVERED: THIS WARRANTY COVERS DEFECTS IN MATERIAL AND WORKMANSHIP ONLY.** This Limited Warranty DOES NOT extend to: (1) Damage caused by shipment; (2) damage caused by accident, misuse, abuse, failure to perform owner maintenance, or operation contrary to the instructions in the Carver Corporation owner's manual; (3) units on which the serial number has been defaced, modified or removed; (4) damage resulting from modification or attempted repair by any person other than authorized by Carver Corporation; and (5) use for industrial, commercial, and/or professional applications.

**WHAT WE WILL PAY FOR:** Carver will pay all labor and material expenses for items covered under this Limited Warranty. See the next section concerning shipping charges.

**WHAT YOU MUST DO TO OBTAIN WARRANTY SERVICE:** In the event your Carver product requires service, write to Carver Corporation (Attention: Customer Service Department), P. O. Box 1237, Lynnwood, Washington 98046-1237 or call the Customer Service Department directly at (206) 775-6245. You will be directed to an Authorized Carver Service Station or receive instructions to ship the unit to the factory. Please save the original shipping carton and packing materials in case shipping is required. Please DO NOT ship Parcel Post. Include a complete description of the problem, the associated components and connections, and a copy of the purchase receipt. Initial shipping costs are not paid by Carver Corporation; return shipping costs will be pre-paid if repairs were covered by the scope of this warranty.

### Shipping Address

CARVER CORPORATION  
20121 - 48th Avenue West  
Lynnwood, WA 98036

**LIMITATIONS OF IMPLIED WARRANTIES:** ALL IMPLIED WARRANTIES FOR MERCHANTABILITY AND FITNESS FOR A PARTICULAR PURPOSE ARE LIMITED IN DURATION TO THE WARRANTY PERIOD FOR YOUR PRODUCT, UNLESS OTHERWISE PROVIDED BY STATE LAW.

**EXCLUSION OF CERTAIN DAMAGES:** IN NO EVENT SHALL CARVER CORPORATION BE LIABLE FOR PROPERTY OR ANY OTHER INCIDENTAL OR CONSEQUENTIAL DAMAGES WHICH MAY RESULT FROM THE FAILURE OF THIS PRODUCT. IF YOUR CARVER PRODUCT PROVES DEFECTIVE IN MATERIAL OR WORKMANSHIP, THE LIABILITY OF CARVER CORPORATION SHALL BE LIMITED TO THE REPAIR OR REPLACEMENT, AT THE OPTION OF CARVER CORPORATION, OF ANY DEFECTIVE PART.

**STATE LAWS MAY DIFFER:** SOME STATES DO NOT ALLOW LIMITATIONS ON HOW LONG AN IMPLIED WARRANTY LASTS AND/OR DO NOT ALLOW THE EXCLUSION OR LIMITATION OF INCIDENTAL OR CONSEQUENTIAL DAMAGES, SO THE ABOVE LIMITATIONS MAY NOT APPLY TO YOU. THIS WARRANTY GIVES YOU SPECIFIC LEGAL RIGHTS, AND YOU MAY HAVE OTHER RIGHTS WHICH VARY FROM STATE TO STATE.

**OTHER IMPORTANT PROVISIONS:** Carver Corporation reserves the right to make changes in design and improvements to its products without the responsibility of installing such changes or improvements on products previously sold by Carver.

We suggest that you attach your purchase receipt to this Warranty and keep both documents in a safe place. Thank you for your choice of a Carver Corporation product.

**NOTE:** The preceding warranty is exclusive to the United States and its possessions and territories. Please see your Carver dealer or distributor for the correct warranty information in your area or locale.

April, 1993

990-00029-00 Rev. C